

DTC	P0985	Shift Solenoid "E" Control Circuit Low (Shift Solenoid Valve SR)
DTC	P0986	Shift Solenoid "E" Control Circuit High (Shift Solenoid Valve SR)

DESCRIPTION

Shifting from 1st to 5th is performed in combination with the ON and OFF operations of the shift solenoid valves S1, S2, SR, SL1 and SL2 which are controlled by the ECM. If an open or short circuit occurs in any of the shift solenoid valves, the ECM controls the remaining normal shift solenoid valves to allow the vehicle to be driven smoothly (See page [AT-35](#)).

DTC No.	DTC Detection Conditions	Trouble Areas
P0985	ECM detects short in solenoid valve SR circuit 2 times when solenoid valve SR is operated. (1-trip detection logic)	<ul style="list-style-type: none"> Short in shift solenoid valve SR circuit Shift solenoid valve SR ECM
P0986	ECM detects open in solenoid valve SR circuit 2 times when solenoid valve SR is not operated. (1-trip detection logic)	<ul style="list-style-type: none"> Open in shift solenoid valve SR circuit Shift solenoid valve SR ECM

MONITOR DESCRIPTION

These DTCs indicate an open or short in the shift solenoid valve SR circuit. When there is an open or short circuit in any shift solenoid valve circuits, the ECM detects the problem, illuminates the MIL and stores the DTC. When the shift solenoid valve SR is ON, if the resistance is 8 Ω or less, the ECM determines that there is a short malfunction in the shift solenoid valve SR circuit.

When the shift solenoid valve SR is OFF, if the resistance is 100 k Ω or more, the ECM determines that the shift solenoid valve SR circuit is open (See page [AT-35](#)).

MONITOR STRATEGY

Related DTCs	P0985: Shift solenoid valve SR/Range check (Low resistance) P0986: Shift solenoid valve SR/Range check (High resistance)
Required sensors/Components	Shift solenoid valve SR
Frequency of operation	Continuous
Duration	0.128 seconds
MIL operation	Immediate
Sequence of operation	None

TYPICAL ENABLING CONDITIONS

P0985: Range check (Low resistance)

The monitor will run whenever the following DTCs are not present.	None
Shift solenoid valve SR	ON
Battery voltage	8 V or more
Ignition switch	ON
Starter	OFF

P0986: Range check (High resistance)

The monitor will run whenever the following DTCs are not present.	None
Shift solenoid valve SR	OFF
Battery voltage	8 V or more
Ignition switch	ON
Starter	OFF

TYPICAL MALFUNCTION THRESHOLDS

P0985: Range check (Low resistance)

Shift solenoid valve SR resistance	8 Ω or less
------------------------------------	-------------

P0986: Range check (High resistance)

Shift solenoid valve SR resistance	100 kΩ or more
------------------------------------	----------------

COMPONENT OPERATING RANGE

Shift solenoid valve SR resistance	11 to 15 Ω at 20°C (68°F)
------------------------------------	---------------------------

WIRING DIAGRAM

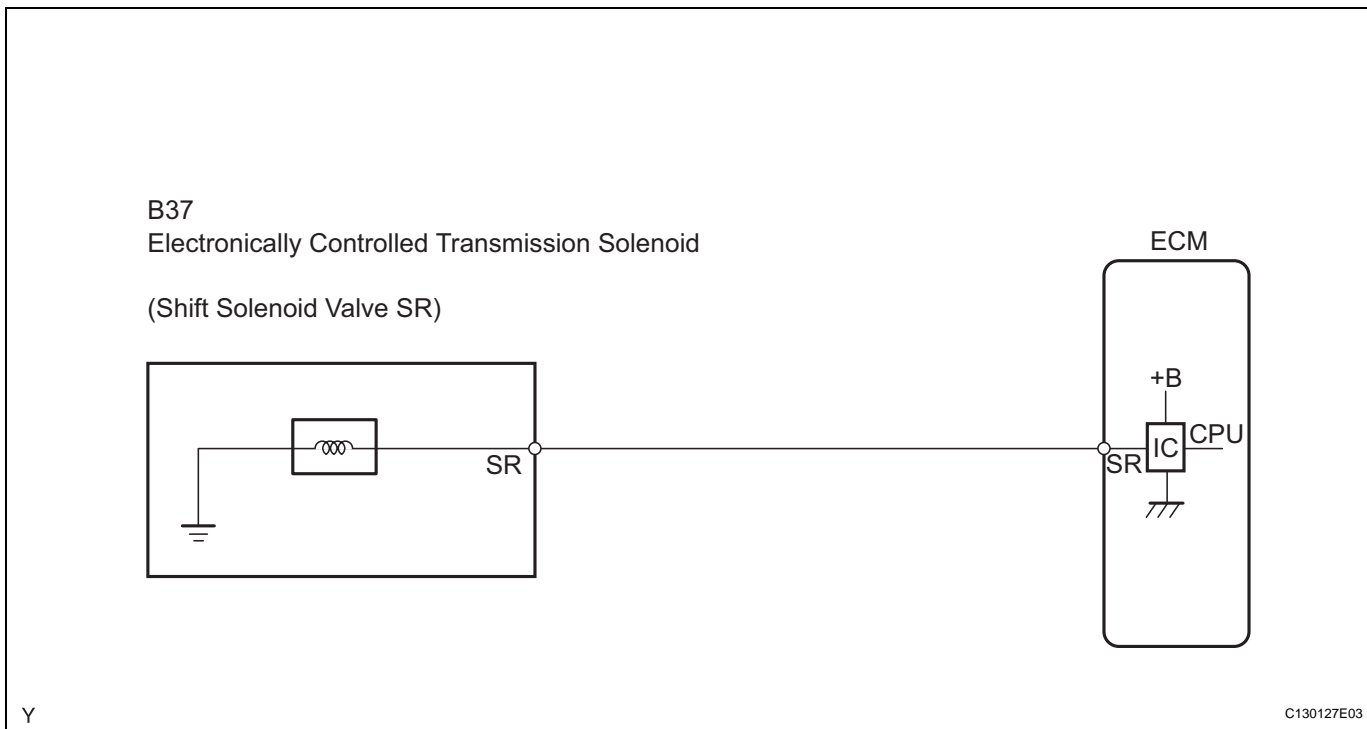

INSPECTION PROCEDURE

HINT:

The shift solenoid valve SR is turned on/off normally when the shift lever is in the D position:

Gearshift controlled by ECM	1st	2nd	3rd	4th	5th
Shift solenoid valve SR	OFF	OFF	OFF	OFF	ON

1 INSPECT TRANSMISSION WIRE (SR)

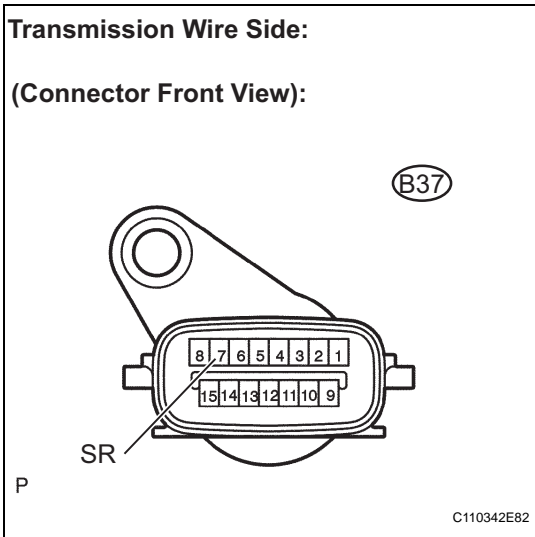

- (a) Disconnect the transmission wire connector from the transmission.
 - (b) Measure the resistance.
- Standard resistance**

Tester Connection	Specified Condition
7 (SR) - Body ground	11 to 15 Ω at 20°C (68°F)

NG → **Go to step 3**

OK

2 CHECK HARNESS AND CONNECTOR (TRANSMISSION WIRE - ECM)

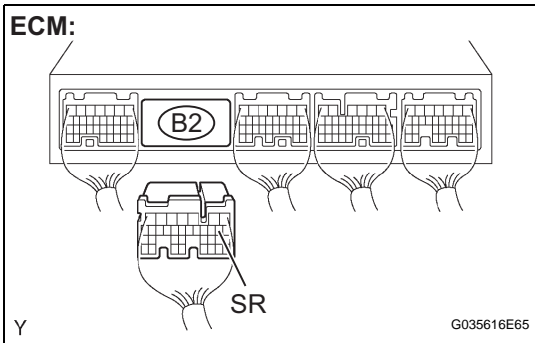

- (a) Connect the transmission wire connector to the transmission.
 - (b) Disconnect the ECM connector.
 - (c) Measure the resistance.
- Standard resistance**

Tester Connection	Specified Condition
B2-9 (SR) - Body ground	11 to 15 Ω at 20°C (68°F)

NG → **REPAIR OR REPLACE HARNESS OR CONNECTOR**

OK

REPLACE ECM

3 INSPECT SHIFT SOLENOID VALVE SR

Shift Solenoid Valve SR:

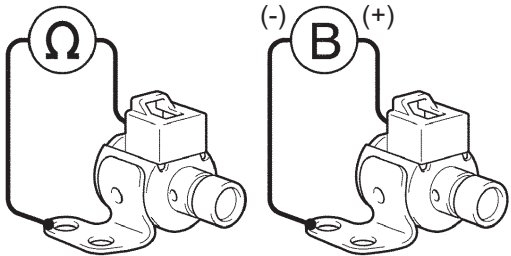

A110988E05

- (a) Remove the shift solenoid valve SR.
- (b) Measure the resistance.

Standard resistance

Tester Connection	Specified Condition
Solenoid Connector (SR) - Solenoid Body (SR)	11 to 15 Ω at 20°C (68°F)

- (c) Connect the positive (+) lead to the terminal of the solenoid connector, and the negative (-) lead to the solenoid body.

OK:

The solenoid makes operating sounds.

NG

REPLACE SHIFT SOLENOID VALVE SR

OK

REPAIR OR REPLACE TRANSMISSION WIRE